

Electronics and Communication Engineering

Set – C

Q.1 - Q.25 Carry one mark each.

1. The value of the integral $\oint_C \frac{-3z+4}{(z^2+4z+5)} dz$ where c is the circle $|z| = 1$ is given by
 (A) 0 (C) 4/5
 (B) 1/10 (D) 1

[Ans. A]

$$\oint_C \frac{-3z+4}{z^2+4z+5} dz = 0 \quad (\because z^2+4z+5 = (z+2)^2+1 = 0)$$

$z = -2 \pm j$ will be outside the unit circle
 So that integration value is 'zero'.

2. In the circuit shown below, the value of R_L such that the power transferred to R_L is maximum is

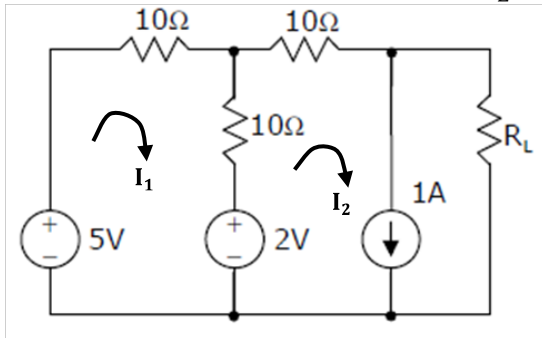

- (A) 5Ω (C) 15Ω
 (B) 10Ω (D) 20Ω

[Ans. C]

$$R_L = R_{th} = 15 \Omega$$

3. In the circuit shown below, the Norton equivalent current in amperes with respect to the terminals P and Q is

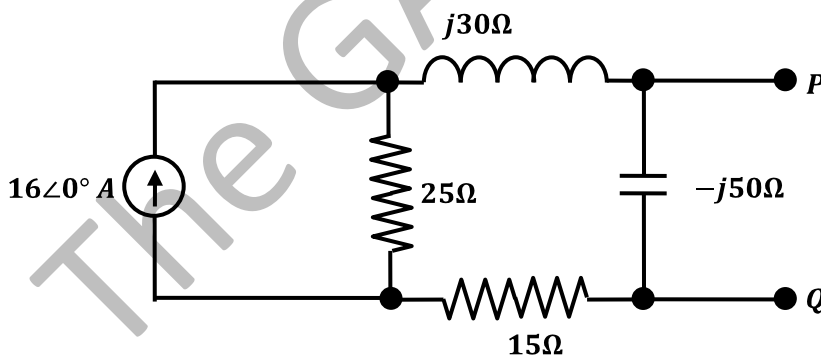

- (A) 6.4 – j4.8 (C) 10 + j0
 (B) 6.56 – j7.87 (D) 16 + j0

[Ans. A]

$$I_N = I_{sh PQ} = 16\angle 0^\circ \times \frac{25}{(40 + j30)} = 8\angle -\tan^{-1}\left(\frac{3}{4}\right) = (6.4 - j4.8) A$$

4. A silicon PN junction is forward biased with a constant current at room temperature. When the temperature is increased by 10°C, the forward bias voltage across the PN junction
 (A) increases by 60 mV (C) increases by 25 mV
 (B) decreases by 60 mV (D) decreases by 25 mV

[Ans. D]

For Si forward bias voltage change by $-2.5\text{mv}/^\circ\text{C}$

For 10°C increases, change will be $-2.5 \times 10 = -25\text{mV}$

5. The circuit below implements a filter between the input current i_i and the output voltage v_o . Assume that the opamp is ideal. The filter implemented is a

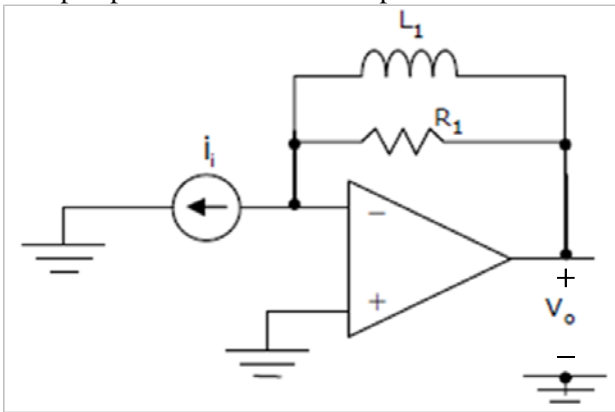

- (A) low pass filter
(B) band pass filter

- (C) band stop filter
(D) high pass filter

[Ans. D]

When $\omega = 0$; inductor acts as a $S.C \Rightarrow V_o = 0$

And when $\omega = \infty$, inductor acts as a $O.C \Rightarrow V_o = i_i R_1$

So it acts as a high pass filter.

6. The logic function implemented by the circuit below is (ground implies a logic “0”)

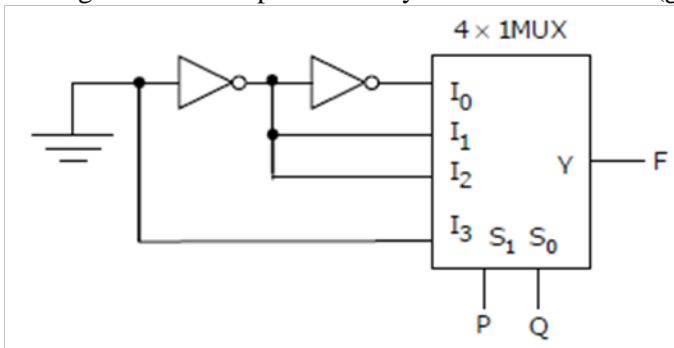

- (A) $F = \text{AND}(P, Q)$
(B) $F = \text{OR}(P, Q)$

- (C) $F = \text{XNOR}(P, Q)$
(D) $F = \text{XOR}(P, Q)$

[Ans. D]

From the CKT

0 is connected to I_0 & I_3

And '1' is connected to I_1 and $I_2 \quad \therefore F = P\bar{Q} + \bar{P}Q = \text{XOR}(P, Q)$

7. When the output Y in the circuit below is “1”, it implies that data has

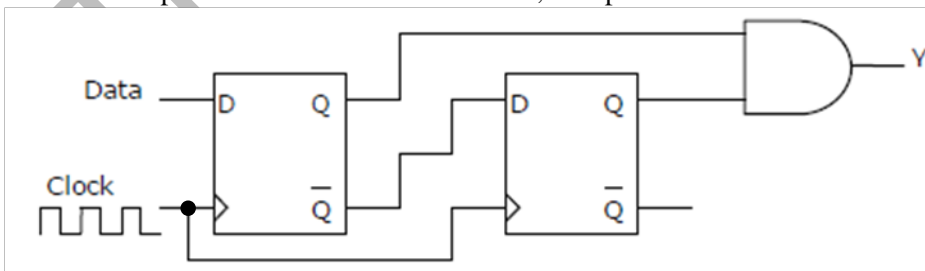

- (A) changed from “0” to “1”
(B) changed from “1” to “0”

- (C) changed in either direction
(D) not changed

[Ans. A]

When data is '0', Q is '0'

And Q' is '1' first flip flop

Data is changed to 1

Q is 1 \rightarrow first 'D'

Q' is connected to 2nd flip flop

So that $Q_2 = 1$

So that the inputs of AND gate is '1' $\Rightarrow y = '1'$

8. The trigonometric Fourier series of an even function does not have the
 (A) dc term (C) sine terms
 (B) cosine terms (D) odd harmonic terms

[Ans. C]

FS expansion of an even function doesn't have sine terms.

9. For the transfer function $G(j\omega) = 5 + j\omega$, the corresponding Nyquist plot for positive frequency has the form

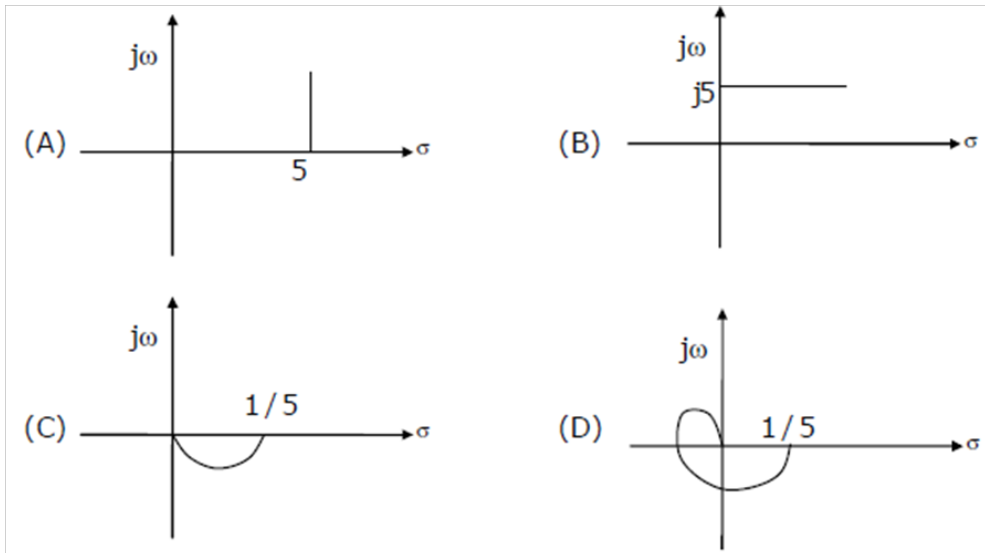

[Ans. A]

$$\omega = 0^+ \Rightarrow G(j\omega) = 5 \angle 0^\circ = 5 + j0$$

$$\omega \rightarrow \infty^+ \Rightarrow G(j\omega) = \infty \angle \pi/2 = 5 + j\infty$$

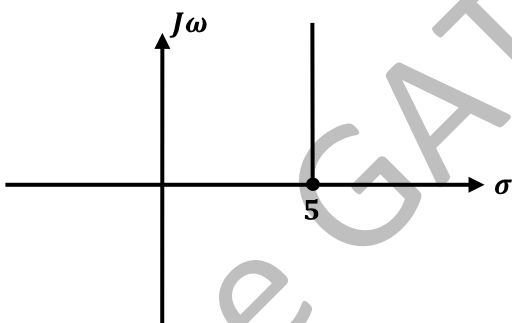

10. The differential equation $100 \frac{d^2y}{dt^2} - 20 \frac{dy}{dt} + y = x(t)$ describes a system with an input $x(t)$ and an output $y(t)$. The system, which is initially relaxed, is excited by a unit step input. The output $y(t)$ can be represented by the waveform

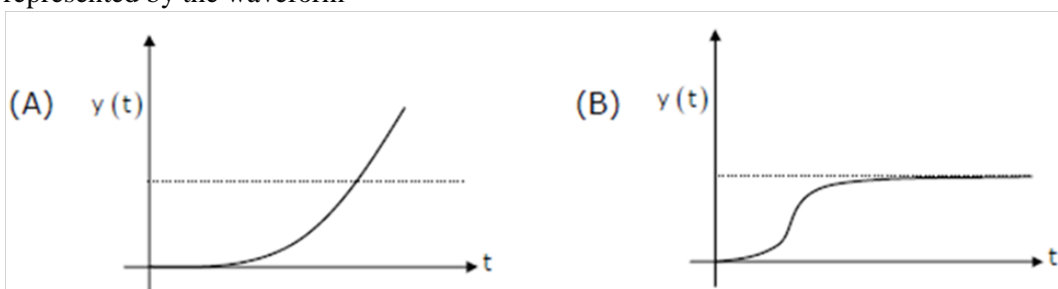

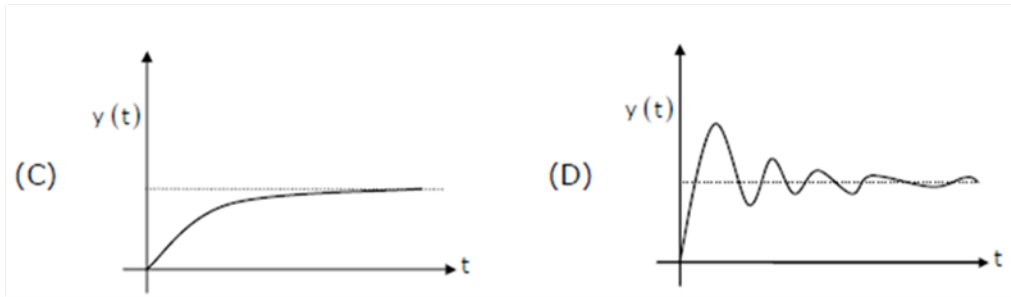

[Ans. A]

Take LT on both sides,

$$\frac{Y(S)}{X(S)} = \frac{1}{(100S^2 - 20S + 1)}$$

$$\text{For } X(S) = 1/S, Y(S) = \frac{1}{100S(S-0.1)^2} = \frac{A}{S} + \frac{B}{(S-0.1)} + \frac{C}{(S-0.1)^2}$$

$$\Rightarrow y(t) = (A + Be^{0.1t} + ct e^{0.1t})u(t)$$

$$\therefore \text{As } t \rightarrow \infty, y(t) \rightarrow \infty$$

11. The Column – 1 lists the attributes and the Column – 2 lists the modulation systems. Match the attribute to the modulation system that best meets it.

Column – 1	Column – 2
P. Power efficient transmission of signals	I. Conventional AM
Q. Most bandwidth efficient transmission of voice signals	II. FM
R. Simplest receiver structure	III. VSB
S. Bandwidth efficient transmission of signals with significant <i>dc</i> component	IV. SSB - SC

(A) P – IV, Q – II, R – I, S – III

(B) P – II, Q – IV, R – I, S – III

(C) P – III, Q – II, R – I, S – IV

(D) P – II, Q – IV, R – III, S – I

[Ans. B]

Power efficient transmission → FM

Most bandwidth efficient → SSB – SC

Transmission of voice signal

Simplest receiver structure → conventional AM

Bandwidth efficient transmission of → VSB

Signals with significant DC component

12. The modes in a rectangular waveguide are denoted by TE_{mn}/TM_{mn} where *m* and *n* are the Eigen numbers along the larger and smaller dimensions of the waveguide respectively. Which one of the following statements is **TRUE**?

(A) The TM_{10} mode of the waveguide does not exist

(B) The TE_{10} mode of the waveguide does not exist

(C) The TM_{10} and the TE_{10} modes both exist and have the same cut – off frequencies

(D) The TM_{10} and the TM_{01} modes both exist and have the same cut – off frequencies

[Ans. A]

TM_{10} mode doesn't exist in rectangular waveguide.

13. The solution of the differential equation $\frac{dy}{dx} = ky, y(0) = c$ is

(A) $x = ce^{-ky}$

(B) $x = ke^{cy}$

(C) $y = ce^{kx}$

(D) $y = ce^{-kx}$

[Ans. C]

$$\text{Given } y(0) = C \text{ and } \frac{dy}{dx} = ky, \Rightarrow \frac{dy}{y} = kdx$$

$$\ln y = kx + c \Rightarrow y = e^{kx} e^c$$

$$\text{When } y(0) = C, y = k_1 e^0 \therefore y = C e^{kx} (\because k_1 = C)$$

14. Consider a closed surface *S* surrounding a volume *V*. If \vec{r} is the position vector of a point inside *S*, with \hat{n} the unit normal of *S*, the value of the integral $\oint_S 5\vec{r} \cdot \vec{n} dS$ is

(A) 3V

(B) 5V

(C) 10V

(D) 15V

[Ans. D]

Apply the divergence theorem

$$\oiint_S 5\vec{r} \cdot \vec{n} \, dx = \iiint_V 5\nabla \cdot \vec{r} \, dV$$

$$= 5(3) \iiint_V dV = 15V \quad (\because \nabla \cdot \vec{r} = 3 \text{ and } \vec{r} \text{ is the position vector})$$

15. The circuit shown below is driven by a sinusoidal input $v_i = V_p \cos(t/RC)$. The steady state output v_o is

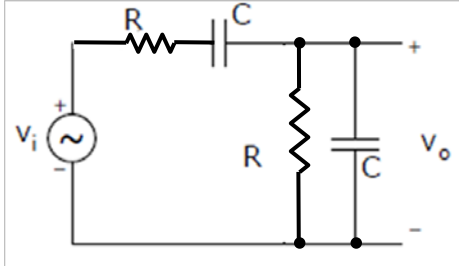

(A) $(V_p/3) \cos(t/RC)$

(B) $(V_p/3) \sin(t/RC)$

(C) $(V_p/2) \cos(t/RC)$

(D) $(V_p/2) \sin(t/RC)$

[Ans. A]

$$H(S) = \frac{R \cdot 1/SC}{(R + 1/SC)^2 + R \cdot 1/SC} = \frac{SRC}{(SRC + 1)^2 + SRC}$$

For $V_i = V_p \cos(t/RC)$, $\omega = 1/RC$ and $V_i = V_p \angle 0^\circ$

$$\therefore S = j\omega = j/RC \Rightarrow H(S) = \frac{J}{(1 + J)^2 + J} = \frac{1}{3}$$

$$\therefore V_o(t) = \frac{V_p}{3} \cos(t/RC)$$

16. A Zener diode, when used in voltage stabilization circuits, is biased in

- (A) Reverse bias region below the breakdown voltage
(B) Reverse breakdown region
(C) Forward bias region
(D) Forward bias constant current mode

[Ans. B]

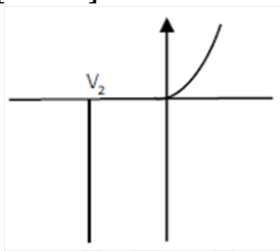

For Zener diode

Voltage remains constant in break down region and current carrying capacity is high.

17. Drift current in semiconductors depends upon

- (A) Only the electric field
(B) Only the carrier concentration gradient
(C) Both the electric field and the carrier concentration
(D) Both the electric field and the carrier concentration gradient

[Ans. C]

Drift current, $J = \sigma E$

$$J = (n\mu_n + p\mu_p)qE$$

So that it depends on carrier concentration and electric field.

18. In the circuit shown below, capacitors C_1 and C_2 are very large and are shorts at the input frequency. v_i is a small signal input. The gain magnitude $|v_o/v_i|$ at 10 Mrad/s is

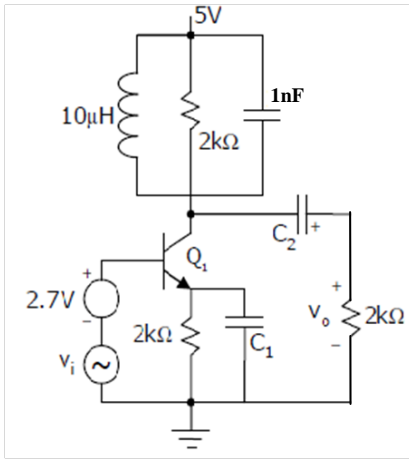

- (A) Maximum
(B) Minimum
(C) Unity
(D) Zero

[Ans. A]

In the parallel RLC Ckt

$$L = 10\mu H \text{ and } C = 1nF$$

$$\omega_g = \frac{1}{\sqrt{LC}} = \frac{1}{\sqrt{10 \times 10^{-6} \times 10^{-9}}} = 10^7 \text{ rad/sec} = 10M\text{rad/s}$$

So that for a tuned amplifier, gain is maximum at resonant frequency

19. The output Y in the circuit below is always “1” when

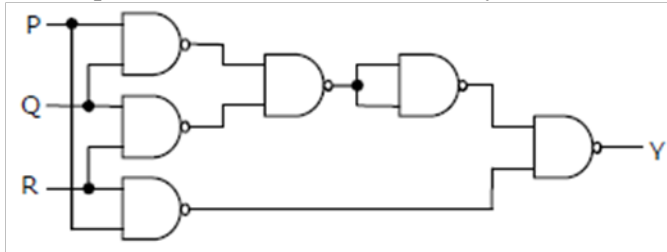

- (A) Two or more of the inputs P, Q, R are “0”
(B) Two or more of the inputs P, Q, R are “1”
(C) Any odd number of the inputs P, Q, R is “0”
(D) Any odd number of the inputs P, Q, R is “1”

[Ans. B]

The output Y expression in the Ckt

$$Y = PQ + PR + RQ$$

So that two or more inputs are ‘1’, Y is always ‘1’.

20. If the unit step response of a network is $(1 - e^{-\alpha t})$, then its unit impulse response is

- (A) $\alpha e^{-\alpha t}$
(B) $\alpha^{-1} e^{-\alpha t}$
(C) $(1 - \alpha^{-1}) e^{-\alpha t}$
(D) $(1 - \alpha) e^{-\alpha t}$

[Ans. A]

$$h(t) = \frac{d}{dt}(y_u(t)) = \alpha \cdot e^{-\alpha t}$$

21. A system is defined by its impulse response $h(n) = 2^n u(n - 2)$. The system is

- (A) Stable and causal
(B) Causal but not stable
(C) Stable but not causal
(D) Unstable and noncausal

[Ans. B]

$$\sum_n |h[n]| \rightarrow \infty \Rightarrow \text{unstable}$$

$$h[n] = 0 \text{ for } n < 0 \Rightarrow \text{causal}$$

22. The root locus plot for a system is given below. The open loop transfer function corresponding to this plot is given by

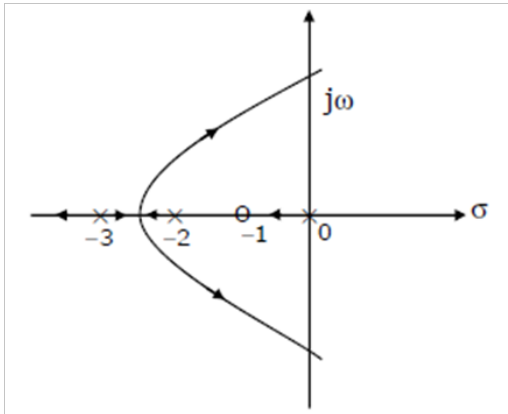

(A) $G(s)H(s) = k \frac{s(s+1)}{(s+2)(s+3)}$

(C) $G(s)H(s) = k \frac{1}{s(s-1)(s+2)(s+3)}$

(B) $G(s)H(s) = k \frac{(s+1)}{s(s+2)(s+3)^2}$

(D) $G(s)H(s) = k \frac{(s+1)}{s(s+2)s+3}$

[Ans. D]

RL starts from open – loop poles and ends at open – loop zeroes. Also RL exists on real axis if number of poles and zeroes to the right of the section is odd.

$$\therefore G(s)H(s) = \frac{K(s+1)}{s(s+2)(s+3)^2}$$

23. An analog signal is band – limited to 4 kHz, sampled at the Nyquist rate and the samples are quantized into 4 levels. The quantized levels are assumed to be independent and equally probable. If we transmit two quantized samples per second, the information rate is

(A) 1 bit/sec

(C) 3 bits/sec

(B) 2 bits/sec

(D) 4 bits/sec

[Ans. D]

Since two samples are transmitted and each sample has 2 bits of information, then the information rate is 4 bits/sec.

24. Consider the following statements regarding the complex Poynting vector \vec{P} for the power radiated by a point source in an infinite homogeneous and lossless medium $\text{Re}(\vec{P})$ denotes the real part of \vec{P} , S denotes a spherical surface whose centre is at the point source, and \hat{n} denotes the unit surface normal on S. Which of the following statements is **TRUE**?

(A) $\text{Re}(\vec{P})$ remains constant at any radial distance for the source

(B) $\text{Re}(\vec{P})$ increases with increasing radial distance from the source

(C) $\iint_S \text{Re}(\vec{P}) \cdot \hat{n} dS$ remains constant at any radial distance from the source

(D) $\iint_S \text{Re}(\vec{P}) \cdot \hat{n} dS$ decreases with increasing radial distance from the source

[Ans. D]

$\iint_S \text{Re}(\vec{P}) \cdot \hat{n} ds$ gives average power and it decreases with increasing radial distance from the source.

25. A transmission line of characteristic impedance 50Ω is terminated by a 50Ω load. When excited by a sinusoidal voltage source at 10 GHz, the phase difference between two points spaced 2 mm apart on the line is found to be $\pi/4$ radians. The phase velocity of the wave along the line is

(A) $0.8 \times 10^8 \text{ m/s}$

(C) $1.6 \times 10^8 \text{ m/s}$

(B) $1.2 \times 10^8 \text{ m/s}$

(D) $3 \times 10^8 \text{ m/s}$

[Ans. A]

Q. 26 to Q. 55 carry two marks each.

26. The system of equations

$$x + y + z = 6$$

$$x + 4y + 6z = 20$$

$$x + 4y + \lambda z = \mu$$

has NO solution for values of λ and μ given by

(A) $\lambda = 6, \mu = 20$

(C) $\lambda \neq 6, \mu = 20$

(B) $\lambda = 6, \mu \neq 20$

(D) $\lambda \neq 6, \mu \neq 20$

[Ans. B]

Given equations are $x + y + z = 6$, $x + 4y + 6z = 20$ and $x + 4y + \lambda z = \mu$

If $\lambda = 6$ and $\mu = 20$, then $x + 4y + 6z = 20$

$x + 4y + 6z = 20$ infinite solution

If $\lambda = 6$ and $\mu \neq 20$, the

$x + 4y + 6z = 20$

($\mu \neq 20$) no solution

$x + 4y + 6z = \mu$

If $\lambda \neq 6$ and $\mu = 20$

$x + 4y + 6z = 20$

Will have solution

$x + 4y + \lambda z = 20$

$\lambda \neq 6$ and $\mu \neq 20$ will also give solution

27. A fair dice is tossed tow times. The probability that the second toss results in a value that is higher than the first toss is

(A) $2/36$

(C) $5/12$

(B) $2/6$

(D) $1/2$

[Ans. C]

Total number of cause = 36

Total number of favorable causes = $5 + 4 + 3 + 2 + 1 = 15$

Then probability = $\frac{15}{36} = \frac{5}{12}$

(1, 1)

(2, 1)

(3, 1)

(4, 1)

(5, 1)

(6, 1)

(1, 2)

(2, 2)

(3, 2)

(4, 2)

(5, 2)

(6, 2)

(1, 3)

(2, 3)

(3, 3)

(4, 3)

(5, 3)

(6, 3)

(1, 4)

(2, 4)

(3, 4)

(4, 4)

(5, 4)

(6, 4)

(1, 5)

(2, 5)

(3, 5)

(4, 5)

(5, 5)

(6, 5)

(1, 6)

(2, 6)

(3, 6)

(4, 6)

(5, 6)

(6, 6)

28. In the circuit shown below, the initial charge on the capacitor is 2.5 mC, with the voltage polarity as indicated. The switch is closed at time $t = 0$. The current $i(t)$ at a time t after the switch is closed is

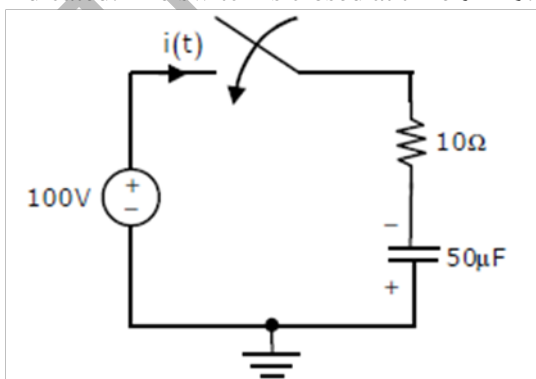

(A) $i(t) = 15 \exp(-2 \times 10^3 t) A$

(C) $i(t) = 10 \exp(-2 \times 10^3 t) A$

(B) $i(t) = 5 \exp(-2 \times 10^3 t) A$

(D) $i(t) = -5 \exp(-2 \times 10^3 t) A$

[Ans. A]

$$\theta(0^-) = -2.5mC \Rightarrow V(0^-) = \frac{Q(0^-)}{C} = \frac{-2.5 \times 10^{-3}}{50 \times 10^{-6}} = -50V$$

For $t \geq 0$, $V_x = -50V$; $V_R = 100V$; $\tau = Req C = 500 \times 10^{-6}$

$$\therefore V_c(t) = (100 - 150 e^{-2000t})u(t)$$

$$\therefore i_c(t) = C \cdot \frac{dV_c}{dt} = 50 \times 10^{-6} \times 150 \times 2000 \times e^{-2000t} u(t) = 15e^{-2000t} u(t)$$

29. In the circuit shown below, the network N is described by the following Y matrix:

$$Y = \begin{bmatrix} 0.1 S & -0.01 S \\ 0.01 S & 0.1 S \end{bmatrix}. \text{ The voltage gain } \frac{V_2}{V_1} \text{ is}$$

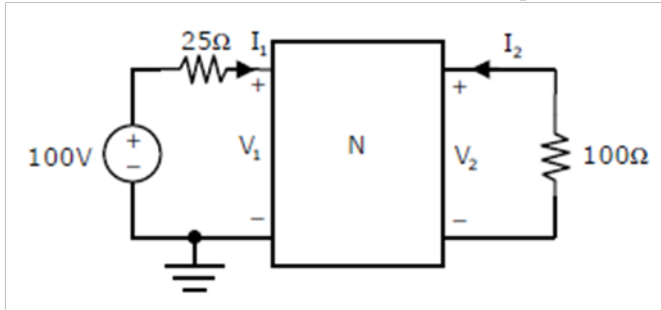

(A) 1/90

(B) -1/90

(C) -1/99

(D) -1/11

[Ans. D]

$$N_1 = 100V + 25I_1; V_2 = -100I_2$$

$$I_2 = Y_3 V_1 + Y_4 V_2 \Rightarrow -0.01V_2 = 0.01V_1 + 0.1V_2 \Rightarrow \frac{V_2}{V_1} = \frac{-1}{11}$$

30. For the BJT Q_1 in the circuit shown below, $\beta = \infty$, $V_{BEon} = 0.7V$, $V_{CEsat} = 0.7V$. The switch is initially closed. At time $t = 0$, the switch is opened. The time t at which Q_1 leaves the active region is

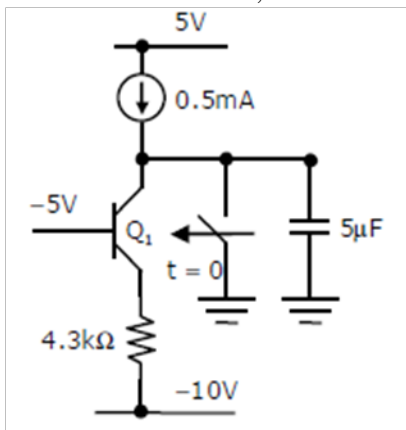

(A) 10 ms

(B) 25 ms

(C) 50 ms

(D) 100 ms

[Ans. C]

Apply KVL at the BE junction

$$I_E = \frac{-5 - 0.7 + 10}{4.3k\Omega} = \frac{4.3}{4.3k\Omega} = 1mA$$

Always $I_E = 1mA$; At collection junction

$$I_{cap} + (0.5mA) = 1mA \quad (\because \beta = \infty; I_E = I_C)$$

$$I_{cap} = 1 - 0.5 = 0.5mA \text{ always constant}$$

$$V_{CE} = V_C - V_E \Rightarrow V_C = V_{CE} + V_E$$

$$= 0.7 + (4.3)3 \times 1 \times 10^{-3} = 0.7 + 4.3 (\because V_E = I_E R_E)$$

$$V_C = 5V = V_{cap}$$

$$V_{cap} = I_{cap} \frac{t}{c} \text{ or } t = \frac{V_{cap} (C)}{I_{cap}} = \frac{(5) \times 5 \times 10^{-6}}{0.5 \times 10^{-3}} = 50ms$$

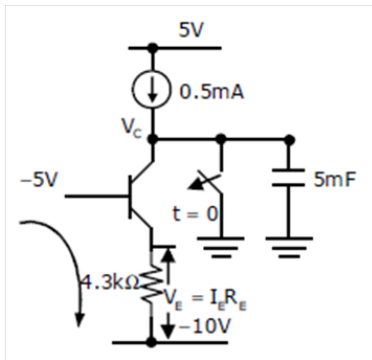

31. The first six points of the 8-point DFT of a real values sequence are $5, 1 - j3, 0, 3 - j4, 0$ and $3 + j4$. The last two points of the DFT are respectively

- (A) $0, 1 - j3$ (C) $1 + j3, 5$
 (B) $0, 1 + j3$ (D) $1 - j3, 5$

[Ans. B]

As signal is real, DFT is conjugate symmetric $\Rightarrow X(K) = X^*(N - K)$

$X(6) = 0$

$X(7) = 1 + j3$

32. An 8085 assembly language program is given below. Assume that the carry flag is initially unset. The content of the accumulator after the execution of the program is

```
MVI A, 07H
RLC
MOV B, A
RLC
RLC
ADD B
RRC
```

- (A) 8CH (C) 23H
 (B) 64H (D) 15H

[Ans. C]

MVI A, 07 H	\Rightarrow 0000	0111	\leftarrow The content of 'A'
RLC	\Rightarrow 0000	1110	\leftarrow The content of 'A'
MOV B, A	\Rightarrow 0000	1110	\leftarrow The content of 'B'
RLC	\Rightarrow 0001	1100	\leftarrow The content of 'B'
RLC	\Rightarrow 0011	1000	\leftarrow The content of 'B'
ADD B			

$$\begin{array}{r}
 \text{A } 0000 \quad 1110 \\
 + \\
 \text{B } 0011 \quad 1000 \\
 \hline
 0100 \quad 0110 \\
 \text{RRC} \rightarrow \frac{0010}{2} \quad \frac{0011}{3} \quad 23H
 \end{array}$$

33. Two system $H_1(z)$ and $H_2(z)$ are connected in cascade as shown below. The overall output $y(n]$ is the same as the input $x(n]$ with a one unit delay. The transfer function of the second system $H_2(z)$ is

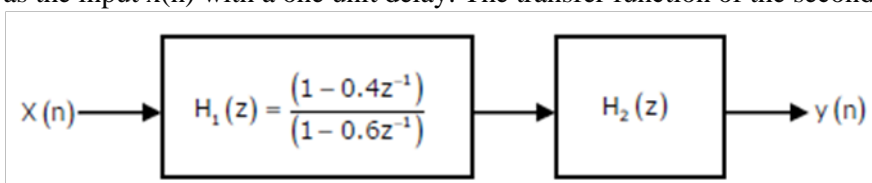

- (A) $\frac{(1 - 0.6z^{-1})}{z^{-1}(1 - 0.4z^{-1})}$ (C) $\frac{z^{-1}(1 - 0.4z^{-1})}{(1 - 0.6z^{-1})}$
 (B) $\frac{z^{-1}(1 - 0.6z^{-1})}{(1 - 0.4z^{-1})}$ (D) $\frac{(1 - 0.4z^{-1})}{z^{-1}(1 - 0.6z^{-1})}$

[Ans. B]

$$y[n] = x[n - 1]$$

$$\Rightarrow H_1(z) \cdot H_2(z) = z^{-1} \Rightarrow H_2(z) = \frac{z^{-1}(1 - 0.6z^{-1})}{(1 - 0.4z^{-1})}$$

34. The block diagram of a system with one input u and two outputs y_1 and y_2 is given below.

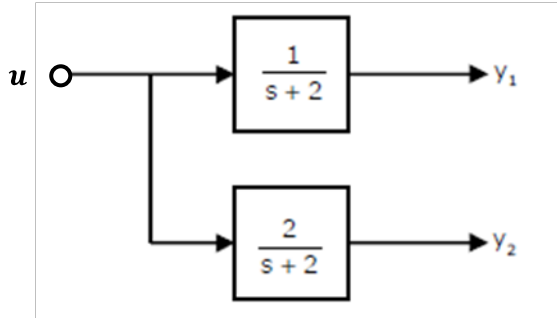

A state space model of the above system in terms of the state vector \underline{x} and the output vector $\underline{y} = [y_1 \ y_2]^T$ is

(A) $\dot{\underline{x}} = [2]\underline{x} + [1]u;$

$\underline{y} = [1 \ 2]\underline{x}$

(C) $\dot{\underline{x}} = \begin{bmatrix} -2 & 0 \\ 0 & -2 \end{bmatrix} \underline{x} + \begin{bmatrix} 1 \\ 1 \end{bmatrix} u;$ $\underline{y} = [1 \ 2]\underline{x}$

(B) $\dot{\underline{x}} = [-2]\underline{x} + [1]u;$

$\underline{y} = \begin{bmatrix} 1 \\ 2 \end{bmatrix} \underline{x}$

(D) $\dot{\underline{x}} = \begin{bmatrix} 2 & 0 \\ 0 & 2 \end{bmatrix} \underline{x} + \begin{bmatrix} 1 \\ 1 \end{bmatrix} u;$ $\underline{y} = \begin{bmatrix} 1 \\ 2 \end{bmatrix} \underline{x}$

[Ans. B]

$$G(s) = C(SI - A)^{-1} B + D$$

For (A), $G(s) = [1 \ 2] \frac{1}{(s-2)} [1] = \left[\frac{1}{s-2} \ \frac{2}{s-2} \right] \Rightarrow$ not correct

For (B), $G(s) = \begin{bmatrix} 1 \\ 2 \end{bmatrix} \left[\frac{1}{s+2} \right] [1] = \begin{bmatrix} 1/s+2 \\ 2/s+2 \end{bmatrix} \Rightarrow$ correct

For (C), $G(s) = [1 \ 2] \frac{1}{(s+2)} \begin{bmatrix} 2 & 0 \\ 0 & 2 \end{bmatrix} \begin{bmatrix} 1 \\ 1 \end{bmatrix} = \frac{6}{(s+2)} \Rightarrow$ not correct

For (D), $G(s) = \begin{bmatrix} 1 \\ 2 \end{bmatrix} \frac{1}{(s-2)} \begin{bmatrix} 2 & 0 \\ 0 & 1 \end{bmatrix} \begin{bmatrix} 1 \\ 1 \end{bmatrix} \Rightarrow$ not correct

35. A message signal $m(t) = \cos 2000\pi t + 4 \cos 4000 \pi t$ modulates the carrier $c(t) = \cos 2\pi f_c t$ where $f_c = 1$ MHz to produce an AM signal. For demodulating the generated AM signal using an envelope detector, the time constant RC of the detector circuit should satisfy

(A) $0.5 \text{ ms} < RC < 1 \text{ ms}$

(C) $RC \ll 1 \mu\text{s}$

(B) $1 \mu\text{s} \ll RC < 0.5 \text{ ms}$

(D) $RC \gg 0.5 \text{ ms}$

[Ans. B]

Time constant should be length than $\frac{1}{f_m}$

And time constant should be far greater than $\frac{1}{f_c}$

$$f_m = \frac{4000a}{2a} = 2000$$

$$\frac{1}{f_c} \ll RC < \frac{1}{2000}$$

$$1\mu\text{s} \ll RC \ll 0.5 \text{ ms}$$

36. The electric and magnetic fields for a TEM wave of frequency 14 GHz in a homogeneous medium of relative permittivity ϵ_r and relative permeability $\mu_r = 1$ are given by

$$\vec{E} = E_p e^{j(\omega t - 280\pi y)} \hat{u}_z \text{ V/m} \quad \vec{H} = 3e^{j(\omega t - 280\pi y)} \hat{u}_x \text{ A/m}$$

Assuming the speed of light in free space to be 3×10^8 m/s, the intrinsic impedance of free space to be 120π , the relative permittivity ϵ_r of the medium and the electric field amplitude E_p are

(A) $\epsilon_r = 3, E_p = 120\pi$

(C) $\epsilon_r = 9, E_p = 360\pi$

(B) $\epsilon_r = 3, E_p = 360\pi$

(D) $\epsilon_r = 9, E_p = 120\pi$

[Ans. D]

$$\frac{E}{H} = \eta = \sqrt{\frac{\mu}{\epsilon}} = 120\pi \sqrt{\frac{\mu_r}{\epsilon_r}}$$

$$\frac{E_p}{3} = \eta = 120\pi \sqrt{\frac{\mu_r}{\epsilon_r}} \text{ Only option 'D' satisfies}$$

37. A numerical solution of the equation $f(x) = x + \sqrt{x} - 3 = 0$ can be obtained using Newton – Raphson method. If the starting value is $x = 2$ for the iteration, the value of x that is to be used in the next step is

(A) 0.306 (C) 1.694

(B) 0.739 (D) 2.306

[Ans. C]

$$x_{n+1} = x_n - \frac{f(x_n)}{f'(x_n)}$$

$$f(2) = (2 + \sqrt{2} - 3) = \sqrt{2} - 1 \text{ and } f'(2) = 1 + \frac{1}{2\sqrt{2}} = \frac{2\sqrt{2}+1}{2\sqrt{2}}$$

$$\Rightarrow x_{n+1} = 2 - \frac{(\sqrt{2} - 1)}{\frac{2\sqrt{2} + 1}{2\sqrt{2}}} = 1.694$$

38. In the circuit shown below, the current I is equal to

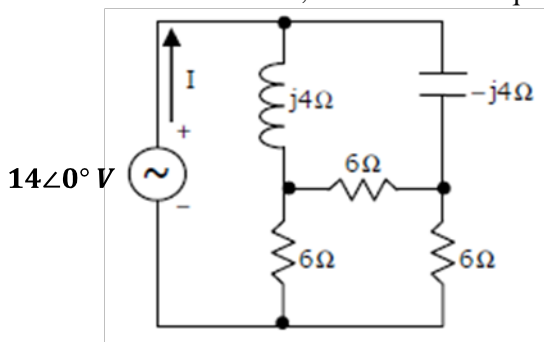

(A) $1.4 \angle 0^\circ \text{ A}$

(B) $2.0 \angle 0^\circ \text{ A}$

(C) $2.8 \angle 0^\circ \text{ A}$

(D) $3.2 \angle 0^\circ \text{ A}$

[Ans. B]

$Z_S = 7 \angle 0^\circ \Omega$ (using Y - Δ transformation)

$$I = \frac{14 \angle 0^\circ}{7 \angle 0^\circ} = 2 \angle 0^\circ \text{ A}$$

39. If $F(s) = L[f(t)] = \frac{2(s+1)}{s^2+4s+7}$ then the initial and final values of $f(t)$ are respectively

(A) 0, 2

(C) 0, 2/7

(B) 2, 0

(D) 2/7, 0

[Ans. B]

$$\lim_{t \rightarrow 0} f(t) = \lim_{s \rightarrow \infty} s \cdot F(s) = 2$$

$$\lim_{t \rightarrow \infty} f(t) = \lim_{s \rightarrow 0} s \cdot F(s) = 0$$

40. For a BJT, the common – base current gain $\alpha = 0.98$ and the collector base junction reverse bias saturation current $I_{CO} = 0.6 \mu\text{A}$. This BJT is connected in the common emitter mode and operated in the active region with a base drive current $I_B = 20 \mu\text{A}$. The collector current I_C for this mode of operation is

(A) 0.98 mA

(C) 1.0 mA

(B) 0.99 mA

(D) 1.01 mA

[Ans. D]

$$I_C = \beta I_B + (1 + \beta) I_{CB0} = \beta = \frac{\alpha}{1 - \alpha} = \frac{0.98}{1 - 0.98} = 49$$

$$I_B = 20 \mu\text{A}, I_{CB0} = 0.6 \mu\text{A} \therefore I_C = 1.01 \text{ mA}$$

41. An input $x(t) = \exp(-2t)u(t) + \delta(t - 6)$ is applied to an LTI system with impulse response $h(t) = u(t)$. The output is

- (A) $[1 - \exp(-2t)]u(t) + u(t + 6)$
 (B) $[1 - \exp(-2t)]u(t) + u(t - 6)$

- (C) $0.5[1 - \exp(-2t)]u(t) + u(t + 6)$
 (D) $0.5[1 - \exp(-2t)]u(t) + u(t - 6)$

[Ans. D]

$$X(s) = \frac{1}{(s+2)} + e^{-6s}; H(s) = \frac{1}{s}$$

$$\therefore Y(s) = \frac{1}{s(s+2)} + \frac{e^{-6s}}{s} = \frac{1}{2s} - \frac{1}{2(s+2)} + \frac{e^{-6s}}{s}$$

$$\Rightarrow y(t) = \frac{1}{2} (1 - e^{-2t}) u(t) + u(t - 6)$$

42. In the circuit shown below, for the MOS transistor, $\mu_n C_{ox} = 100 \mu A/V^2$ and the threshold voltage $V_T = 1V$. The voltage V_x at the source of the upper transistor is

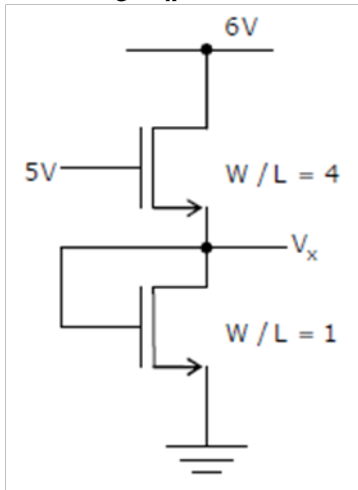

- (A) 1 V
 (B) 2 V
 (C) 3 V
 (D) 3.67 V

[Ans. C]

The transistor which has $\frac{W}{L} = 4$

$$V_{DS} = 6 - V_x \text{ and } V_{GS} = 5 - V_x$$

$$V_{GS} - V_T = 5 - V_x - 1 = 4 - V_x$$

$$V_{DS} > V_{GS} - V_T$$

So that transistor in saturation region.

The transistor which has $\frac{W}{L} = 1$

Drain is connected to gate

So that transistor in saturation

$$V_{DS} > V_{GS} > V_T \quad (\because V_{DS} = V_{GS})$$

The current flow in both the transistor is same

$$\mu_n C_{ox} \left(\frac{W}{L}\right)_1 \left(\frac{(V_{GS})_1 - V_T}{2}\right)^2 = \mu_n C_{ox} \left(\frac{W}{L}\right)_2 \cdot \left(\frac{(V_{GS})_2 - V_T}{2}\right)^2$$

$$4 \frac{(5 - V_x - 1)^2}{2} = 1 \frac{(V_x - 4)^2}{2} \quad (\because V_{GS} = V_x - 0)$$

$$4(V_x^2 - 8V_x + 16) = V_x^2 - 2V_x + 1 \Rightarrow 3V_x^2 - 30V_x + 63 = 0 \Rightarrow V_x = 3V$$

43. Two D flip – flops are connected as a synchronous counter that goes through the following $Q_B Q_A$ sequence $00 \rightarrow 11 \rightarrow 01 \rightarrow 10 \rightarrow 00 \rightarrow \dots$

The connections to the inputs D_A and D_B are

- (A) $D_A = Q_B, D_B = \overline{Q_A}$
 (B) $D_A = \overline{Q_A}, D_B = \overline{Q_B}$
 (C) $D_A = (Q_A \overline{Q_B} + \overline{Q_A} Q_B), D_B = Q_A$
 (D) $D_A = (Q_A Q_B + \overline{Q_A} \overline{Q_B}), D_B = \overline{Q_B}$

[Ans. D]

Q (present)		Q (next)		D_B	D_A
Q_B	Q_A	Q_B^1	Q_A^1		
0	0	1	1	1	1
1	1	0	1	0	1

0	1	1	0	1	0
1	0	0	0	0	0

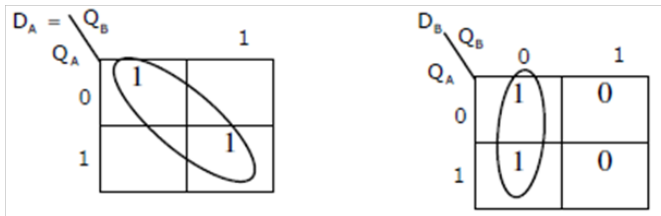

44. The output of a 3 – stage Johnson (twisted – ring) counter is fed to a digital – to – analog (D/A) converter as shown in the figure below. Assume all states of the counter to be unset initially. The waveform which represents the D/A converter output V_0 is

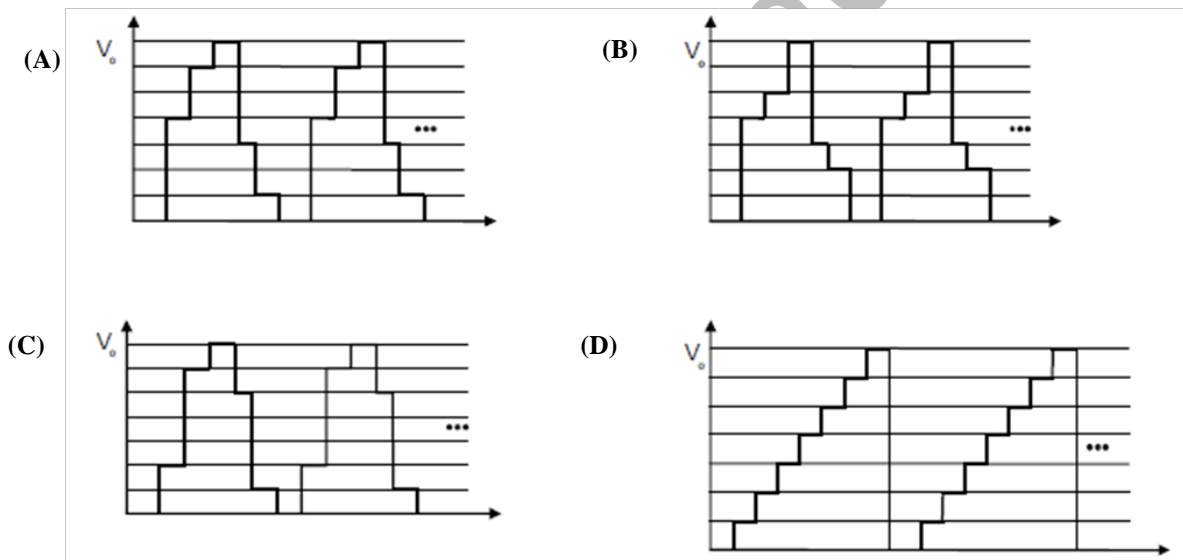
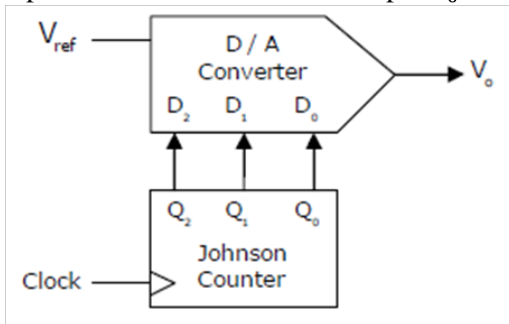

[Ans. A]

For the Johnson counter sequence

$D_2 D_1 D_0$	V_0
0 0 0	1
1 0 0	4
1 1 0	6
1 1 1	7
0 1 1	3
0 0 1	1
0 0 0	0

45. $X(t)$ is a stationary random process with autocorrelation function $R_X(\tau) = \exp(-\pi\tau^2)$. This process is passed through the system shown below. The power spectral density of the output process $Y(t)$ is

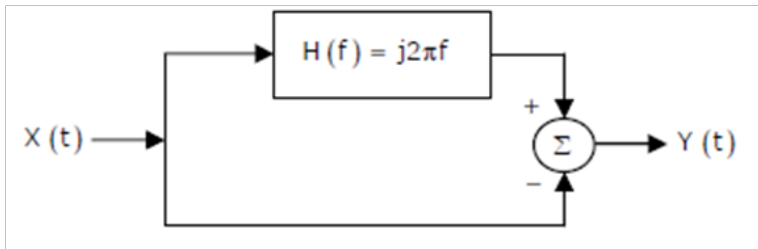

- (A) $(4\pi^2 f^2 + 1) \exp(-\pi f^2)$ (C) $(4\pi^2 f^2 + 1) \exp(-\pi f)$
 (B) $(4\pi^2 f^2 - 1) \exp(-\pi f^2)$ (D) $(4\pi^2 f^2 - 1) \exp(-\pi f)$

[Ans. A]

The total transfer function $H(f) = (j2\pi f - 1)$

$$S_x(f) = |H(f)|^2 S_x(f) R_x(\tau) \leftrightarrow S_x(f)$$

$$= (4\pi^2 f^2 + 1) e^{-\pi f^2} \left(\because e^{-\pi t^2} \leftrightarrow e^{-\pi f^2} \right)$$

46. A current sheet $\vec{J} = 10\hat{u}_y$ A/m lies on the dielectric interface $x = 0$ between two dielectric media with $\epsilon_{r1} = 5, \mu_{r1} = 1$ in Region - 1 ($x < 0$) and $\epsilon_{r2} = 2, \mu_{r2} = 2$ in Region - 2 ($x > 0$). If the magnetic field in Region - 1 at $x = 0^-$ is $\vec{H}_1 = 3\hat{u}_x + 30\hat{u}_y$ A/m, the magnetic field in Region - 2 at $x = 0^+$ is

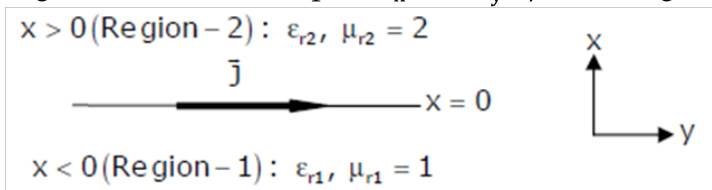

- (A) $\vec{H}_2 = 1.5\hat{u}_x + 30\hat{u}_y - 10\hat{u}_z$ A/m (C) $\vec{H}_2 = 1.5\hat{u}_x + 40\hat{u}_y$ A/m
 (B) $\vec{H}_2 = 3\hat{u}_x + 30\hat{u}_y - 10\hat{u}_z$ A/m (D) $\vec{H}_2 = 3\hat{u}_x + 30\hat{u}_y + 10\hat{u}_z$ A/m

[Ans. A]

$$H_{t2} - H_{t1} = \vec{J} \times \vec{a}_n \Rightarrow H_{t2} = H_{t1} - 10\hat{u}_z = 30\hat{u}_y - 10\hat{u}_z$$

$$\text{And } B_{n1} = B_{n2}$$

$$\mu_1 H_1 = \mu_2 H_2 \Rightarrow H_2 = \frac{\mu_1}{\mu_2} H_1$$

Normal component in x direction

$$H_2 = \frac{1}{2}(3)\hat{u}_x = 1.5\hat{u}_x; H_2 = 1.5\hat{u}_x + 30\hat{u}_y - 10\hat{u}_z \text{ A/m}$$

47. A transmission line of characteristic impedance 50Ω is terminated in a load impedance Z_L . The VSWR of the line is measured as 5 and the first of the voltage maxima in the line is observed at a distance of $\lambda/4$ from the load. The value of Z_L is

- (A) 10Ω (C) $(19.23 + j46.15) \Omega$
 (B) 250Ω (D) $(19.23 - j46.15) \Omega$

[Ans. A]

Voltage maximum in the line is observed exactly at $\frac{\lambda}{4}$

Therefore ' z_L ' should be real

$$VSWR = \frac{z_0}{z_L} \Rightarrow z_L = \frac{50}{5} = 10\Omega \quad (\because \text{Voltage minimum at load})$$

Common Data Question:

Common Data for Question Q. 48 and Q. 49:

The input - output transfer function of a plant $H(s) = \frac{100}{s(s+10)^2}$. The plant is placed in a unity negative feedback configuration as shown in the figure below.

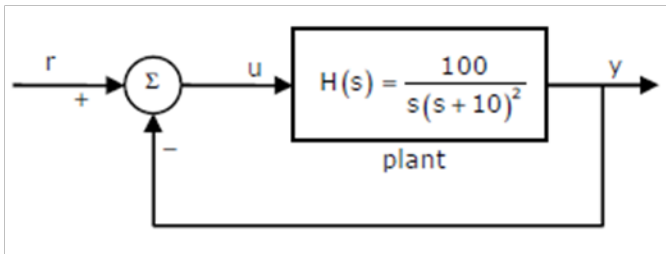

48. The signal flow graph that DOES NOT model the plant transfer function $H(s)$ is

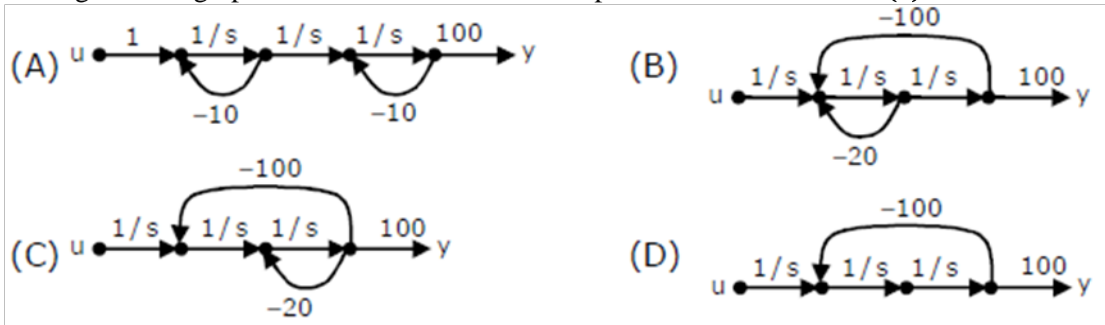

[Ans. D]

From (A),

$$P_1 = \frac{100}{s^3}; L_1 = \frac{-10}{s}; L_2 = \frac{-10}{s}; \Delta_1 = 1; \Delta = 1 + \frac{20}{s} + \frac{100}{s^2} = \frac{(s+10)^2}{s^2}$$

$$\therefore H(s) = \frac{P_1 \Delta_1}{\Delta} = \frac{100}{s(s+10)^2}$$

From (B),

$$P_1 = 100/s^3; L_1 = -100/s^2; L_2 = -20/s; \Delta_1 = 1; \Delta = 1 + \frac{100}{s^2} + \frac{20}{s} = \frac{(s+10)^2}{s^2}$$

$$\therefore H(s) = \frac{P_1 \Delta_1}{\Delta} = \frac{100}{s(s+10)^2}$$

From (C),

$$P_1 = 100/s^3; L_1 = \frac{-100}{s^2}; L_2 = \frac{-20}{s}; \Delta_1 = 1; \Delta = 1 + \frac{100}{s^2} + \frac{20}{s} = \frac{(s+10)^2}{s^2}$$

$$\therefore H(s) = \frac{P_1 \Delta_1}{\Delta} = \frac{100}{s(s+10)^2}$$

From (D),

$$P_1 = 100/s^3; L_1 = -100/s^2; \Delta_1 = 1; \Delta = 1 + \frac{100}{s^2} = \frac{(s^2+100)}{s^2}$$

$$\therefore H(s) = \frac{P_1 \Delta_1}{\Delta} = \frac{100}{s(s^2+100)}$$

49. The gain margin of the system under closed loop unity negative feedback is

- (A) 0 dB (C) 26 dB
(B) 20 dB (D) 46 dB

[Ans. B]

$$OLTF = \frac{100}{s(s+10)^2} \Rightarrow H(j\omega) = \frac{100}{j\omega(10+j\omega)^2}$$

$$\text{Im}(H(j\omega)) = 0 \Rightarrow \omega_p = 10 \text{ rad/sec}$$

$$|H(j\omega)| = \left| \frac{100}{j10(10+j10)^2} \right| = \frac{1}{20}$$

$$\therefore Gm = 20 \log_{10} \left| \frac{1}{H(j\omega)} \right| = 20 \text{ db}$$

Common Data for Question Q. 50 and Q. 51:

The channel resistance of an N – channel JFET shown in the figure below is 600Ω when the full channel thickness (t_{ch}) of $10 \mu\text{m}$ is available for conduction. The built – in voltage of the gate P^+N junction (V_{bi}) is

-1 V. When the gate to source voltage (V_{GS}) is 0 V, the channel is depleted by $1 \mu\text{m}$ on each side due to the built-in voltage and hence the thickness available for conduction is only $8 \mu\text{m}$.

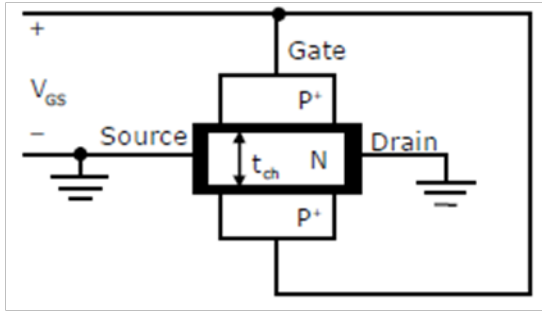

50. The channel resistance when $V_{GS} = 0 \text{ V}$ is

- (A) 480Ω
(B) 600Ω

- (C) 750Ω
(D) 1000Ω

[Ans. C]

$$r_{\text{don}} \propto \frac{1}{t_{\text{oh}}}$$

At $V_{GS} = 0$, $t_{\text{ch}} = 10 \mu\text{m}$; (Given $r_d = 600 \Omega$)

$$r_d = \frac{10}{8} \times 600 \leftarrow \text{at } 8 \mu\text{m} = 750 \Omega$$

51. The channel resistance when $V_{GS} = -3 \text{ V}$ is

- (A) 360Ω
(B) 917Ω

- (C) 1000Ω
(D) 3000Ω

[Ans. C]

Width of the depletion large $W \propto \sqrt{V_{bi} + V_{GS}}$

$$\frac{W_2}{W_1} = \sqrt{\frac{-1-3}{-1}} \Rightarrow w_2 = 2w_1 = 2(1 \mu\text{m}) = 2 \mu\text{m}$$

So that channel thickness = $10 - 4 = 6 \mu\text{m}$

$$8 \mu\text{m} - 750$$

$$6 \mu\text{m} - ?$$

$$r_d = \frac{8}{6} \times 750 = 1000 \Omega$$

Linked Answer Questions:

Statement for Linked Answer Questions Q. 52 and Q. 53:

A four-phase and an eight-phase signal constellation are shown in the figure below.

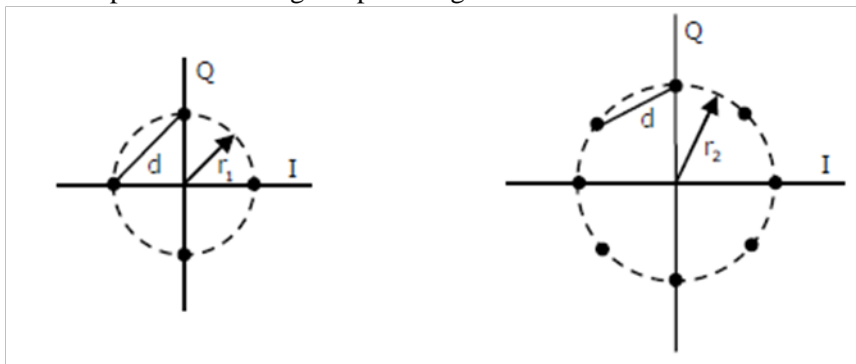

52. For the constraint that the minimum distance between pairs of signal points be d for both constellations, the radii r_1 and r_2 of the circles are

- (A) $r_1 = 0.707d, r_2 = 2.782d$
(B) $r_1 = 0.707d, r_2 = 1.932d$

- (C) $r_1 = 0.707d, r_2 = 1.545d$
(D) $r_1 = 0.707d, r_2 = 1.307d$

[Ans. D]

For 1st constellation

$$r_1^2 + r_1^2 = d^2 \Rightarrow r_1^2 = d^2/2 \Rightarrow r_1 = 0.707d$$

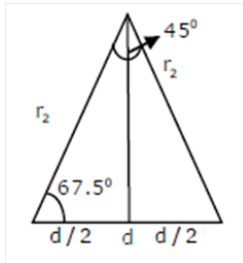

For 2nd constellation

$$\frac{d}{2} = r_2 \cos 67.5$$

$$r_2 = 1.307d$$

53. Assuming high SNR and that all signals are equally probable, the additional average transmitted signal energy required by the 8-PSK signal to achieve the same error probability as the 4-PSK signal is
- (A) 11.90 dB (C) 6.79 dB
(B) 8.73 dB (D) 5.33 dB

[Ans. D]

$$\text{Energy} = r_1^2 \text{ and } r_2^2 \Rightarrow \frac{r_1^2}{r_2^2} = \frac{(0.707d)^2}{(1.307d)^2}$$

$$\text{Energy (in dB)} = 10 \log \frac{(1.307)^2}{(0.707)^2} = 5.33 \text{ dB}$$

Statements for Linked Answer Questions Q. 54 and Q. 55:

In the circuit shown below, assume that the voltage drop across a forward biased diode is 0.7 V. The thermal voltage $V_t = \frac{kT}{q} = 25 \text{ mV}$. The small signal input $v_i = V_p \cos(\omega t)$ where $V_p = 100 \text{ mV}$.

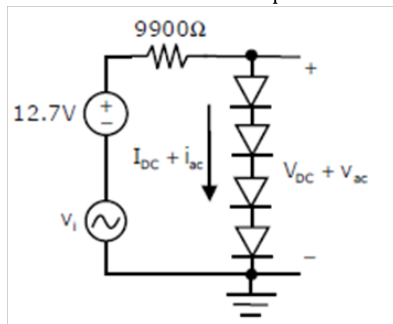

54. The bias current I_{DC} through the diodes is
- (A) 1 mA (C) 1.5 mA
(B) 1.28 mA (D) 2 mA

[Ans. A]

$$I_{DC} = \frac{12.7 - (0.7 + 0.7 + 0.7 + 0.7)}{9900} = 1 \text{ mA}$$

55. The ac output voltage v_{ac} is
- (A) $0.25 \cos(\omega t) \text{ mV}$ (C) $2 \cos(\omega t) \text{ mV}$
(B) $1 \cos(\omega t) \text{ mV}$ (D) $22 \cos(\omega t) \text{ mV}$

[Ans. C]

$$\text{AC dynamic resistance, } r_d = \frac{\eta V_T}{I_D} = \frac{2 \times 25 \text{ mV}}{1 \text{ mA}} = 50 \Omega$$

$\eta = 2$ for Si (\because forward drop = 0.7V)

The ac dynamic resistance offered by each diode = 50Ω

$$\therefore V_{ac} = V_i(ac) \left[\frac{4 \times 50 \Omega}{9900 \times 50} \right] = 200 \times 10^{-3} \cos \omega t \left[\frac{100}{10000} \right]$$

$$V_{ac} = 2 \cos(\omega t) \text{ mV}$$

General Aptitude (GA) Questions

Q. 56 – Q. 60 carry one marks each.

56. Choose the most appropriate word from the options given below to complete the following sentence:
It was her view that the country's problems had been _____ by foreign technocrats, so that to invite them to come back would be counter – productive.

(A) identified (C) exacerbated
(B) ascertained (D) analysed

[Ans. C]

The clues in the question are --- foreign technocrats did something negatively to the problem – so it is counter-productive to invite them. All other options are non-negative. The best choice is exacerbated which means aggravated or worsened.

57. Choose the word from the options given below that is most nearly opposite in meaning to the given word:

Frequency

(A) Periodicity (C) Gradualness
(B) Rarity (D) Persistency

[Ans. B]

The best antonym here is rarity which means shortage or scarcity.

58. Choose the most appropriate word from the options given below to complete the following sentence:
Under ethical guidelines recently adopted by the Indian Medical Association, human genes are to be manipulated only to correct diseases for which _____ treatments are unsatisfactory.

(A) similar (C) uncommon
(B) most (D) available

[Ans. D]

The context seeks to take a deviation only when the existing/present/current/alternative treatments are unsatisfactory. So the word for the blank should be a close synonym of existing/present/current/alternative. Available is the closest of all.

59. The question below consists of a pair of related words followed by four pairs of words. Select the pair that best expresses the relation in the original pair:

Gladiator : Arena

(A) dancer : stage (C) teacher : classroom
(B) commuter : train (D) lawyer : courtroom

[Ans. D]

The given relationship is worker: workplace. A gladiator is (i) a person, usually a professional combatant trained to entertain the public by engaging in mortal combat with another person or a wild. (ii) A person engaged in a controversy or debate, especially in public.

60. There are two candidates P and Q in an election. During the campaign, 40% of the voters promised to vote for P, and rest for Q. However, on the day of election 15% of the voters went back on their promise to vote for P and instead voted for Q. 25% of the voters went back on their promise to vote for Q and instead voted for P. Suppose, P lost by 2 votes, then what was the total number of voters?

(A) 100 (C) 90
(B) 110 (D) 95

[Ans. A]

P	Q
40%	60%
-6%	+6%
+15%	-15%
49%	51%

$$\therefore 2\% = 2$$

$$100\% = 100$$

Q. 61 to Q. 65 carry two marks each

61. Three friends, R, S and T shared toffee from a bowl. R took $\frac{1}{3}$ rd of the toffees, but returned four to the bowl. S took $\frac{1}{4}$ th of what was left but returned three toffees to the bowl. T took half of the remainder but returned two back into the bowl. If the bowl had 17 toffees left, how many toffees were originally there in the bowl?

- (A) 38 (C) 48
(B) 31 (D) 41

[Ans. C]

Let the total number of toffees in bowl be x

R took $\frac{1}{3}$ of toffees and returned 4 to the bowl

$$\therefore \text{Number of toffees with R} = \frac{1}{3}x - 4$$

$$\text{Remaining of toffees in bowl} = \frac{2}{3}x + 4$$

$$\text{Number of toffees with S} = \frac{1}{4} \left(\frac{2}{3}x + 4 \right) - 3$$

$$\text{Remaining toffees in bowl} = \frac{3}{4} \left(\frac{2}{3}x + 4 \right) + 4$$

$$\text{Number of toffees with T} = \frac{1}{2} \left(\frac{3}{4} \left(\frac{2}{3}x + 4 \right) + 4 \right) + 2$$

$$\text{Remaining toffees in bowl} = \frac{1}{2} \left[\frac{3}{4} \left(\frac{2}{3}x + 4 \right) + 4 \right] + 2$$

$$\text{Given, } \frac{1}{2} \left[\frac{3}{4} \left(\frac{2}{3}x + 4 \right) + 4 \right] + 2 = 17 \Rightarrow \frac{3}{4} \left(\frac{2}{3}x + 4 \right) = 27 \Rightarrow x = 48$$

62. Given that $f(y) = |y|/y$, and q is any non-zero real number, the value of $|f(q) - f(-q)|$ is

- (A) 0 (C) 1
(B) -1 (D) 2

[Ans. D]

$$\text{Given, } f(y) = \frac{|y|}{y} \Rightarrow f(q) = \frac{|q|}{q}; f(-q) = \frac{|-q|}{-q} = \frac{-|q|}{q}$$

$$|f(q) - f(-q)| = \frac{|q|}{q} + \frac{|q|}{q} = \frac{2|q|}{q} = 2$$

63. The sum of n terms of the series $4 + 44 + 444 + \dots$ is

- (A) $(4/81) [10^{n+1} - 9n - 1]$ (C) $(4/81) [10^{n+1} - 9n - 10]$
(B) $(4/81) [10^{n-1} - 9n - 1]$ (D) $(4/81) [10^n - 9n - 10]$

[Ans. C]

$$\text{Let } S = 4(1 + 11 + 111 + \dots) = \frac{4}{9} (9 + 99 + 999 + \dots)$$

$$= \frac{4}{9} \{ (10 - 1) + (10^2 - 1) + (10^3 - 1) + \dots \}$$

$$= \frac{4}{9} \{ (10 + 10^2 + \dots + 10^n) - n \} = \frac{4}{9} \left\{ 10 \frac{(10^n - 1)}{9} - n \right\} = \frac{4}{81} \{ 10^{n+1} - 9n - 10 \}$$

64. **The horse has played a little known but very important role in the field of medicine. Horses were injected with toxins of diseases until their blood built up immunities. Then a serum was made from their blood. Serums to fight with diphtheria and tetanus were developed this way.**

It can be inferred from the passage, that horses were

- (A) given immunity to diseases (C) given medicines to fight toxins
(B) generally quite immune to diseases (D) given diphtheria and tetanus serums

[Ans. B]

From the passage it cannot be inferred that horses are given immunity as in (A), since the aim is to develop medicine and in turn immunize humans. (B) is correct since it is given that horses develop immunity after some time. Refer "until their blood built up immunities". Even (C) is invalid since medicine is not built till immunity is developed in the horses. (D) is incorrect since specific examples are cited to illustrate and this cannot capture the essence.

65. The fuel consumed by a motorcycle during a journey while traveling at various speeds is indicated in the graph below.

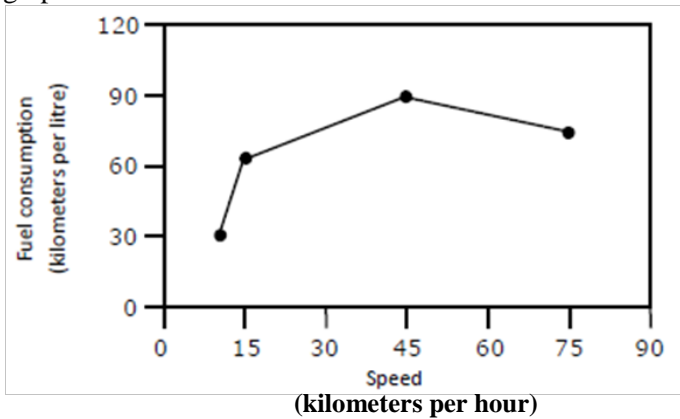

The distances covered during four laps of the journey are listed in the table below

Lap	Distance (kilometers)	Average speed (kilometers per hour)
P	15	15
Q	75	45
R	40	75
S	10	10

From the given data, we can conclude that the fuel consumed per kilometer was least during the lap

- (A) P (C) R
(B) Q (D) S

[Ans. A]

	Fuel consumption	Actual
P	60 km/l	$\frac{15}{60} = \frac{1}{4} l$
Q	90 km/l	$\frac{75}{90} = \frac{5}{6} l$
R	75 km/l	$\frac{40}{75} = \frac{8}{15} l$
S	30 km/l	$\frac{10}{30} = \frac{1}{3} l$